



# DAMATI

**20 years** of being leading manufacturers  
of reusable plastic food containers

**PRODUCT  
CATALOGUE  
2023**





## ABOUT US

Damati, established in **2003**, specializes in manufacturing and export of all types of Plastic products, primarily supplied to a significant clientele in the Food Packaging Industry.

Founded and owned by **Mr. Sunil K. Parwani**. Damati is a family run business that has steadily grown to be recognized as a market leader in the Food Packaging Industry, for its range of multi-purpose products.



At Damati, our vision is to be recognized as a leading plastic takeaway food containers manufacturing company providing quality product. We strive to maintain long term relationships that are rewarding and favourable to all involved. Damati is devoted to a culture of endless development.





“We are humbled by Damati being recognized as a global name in the food packaging industry. Our experience in the industry, and the facilities we are operating, give us the added benefit of acting as an OEM supplier to companies that source plastic products of any specifications. Our vision is to supply quality products for various industry applications, and grow with our vendor and client partners.”

**MR. SUNIL PARWANI - FOUNDER**



## OUR MISSION

Our mission is to deliver high-quality products along with plastic food containers with lids, that exceed our customers’ expectations. We strive for innovation while building ethical relationships with our customers and suppliers, through our products, to achieve long-term success.





## Why Damati?

We at Damati productively benefit from **20 years** of experience in the domestic market and international market.

Constantly innovating alongside the market, Damati stays up to date with technology and designs. We relentlessly strive to achieve customer satisfaction by staying in sync with relevant technology and design updates worldwide, resulting in high-quality products for our end users.



RECYCLABLE



REUSABLE



BPA FREE



MICROWAVE FRIENDLY



FOOD GRADE



FREEZER-PROOF



HYGIENIC



CFC FREE



DISHWASHER SAFE



DURABLE



ODOURLESS



CUSTOM DESIGNING



LEAK RESISTANT



FOR OEMS



CUSTOMISED TOOLS  
FOR MOULDING



GLOBAL HAPPY  
CUSTOMERS



# INFRASTRUCTURE

## OUR PRESENCE

Damati's corporate office stands in **Mumbai** while our manufacturing facilities include 3 plants, a Plastic Products Manufacturing Plant in **Daman, Vasai** and **Silvassa**.



**DAMAN**  
MANUFACTURING PLANT

**SILVASSA**  
MANUFACTURING PLANT

**MUMBAI**  
CORPORATE OFFICE

**UAE**  
WAREHOUSE

**VASAI**  
MANUFACTURING PLANT

Ethical and quality enforced manufacturing plants being our core asset, our in-house operations include:

## OUR STRUCTURE





## COUNTRIES WE DELIVER TO



 United Kingdom

 USA

 UAE

 Bahrain

 Oman

 Kuwait

 Qatar

 Spain

 Netherlands

 Saudi

 India

 Cyprus

 Belgium

 France

 Australia

 Czech Republic

 Ireland

 Israel

 Greece

 Russia

 Egypt



# OUR SALIENT FEATURES

## TECHNOLOGICAL SUPERIORITY

In-House re-engineered robot technology, Dedicated R&D Facility for labels, Constant Innovation Hot runner moulds.

## END TO END INTEGRATED SERVICES

Complete backward integration, Vast infrastructure & manufacture capacity, World class injection Moulding Machines.

## BEST CUSTOMER SERVICE

ERP in place for perfect execution of orders, Customisabilty & flexibility, Controlled production & dispatch stations and quick transportaion facilities.

## COST ADVANTAGE

We provide excellent quality at competitive prices with reduced transportation costs due to worldwide sales and distribution network.





# Hinge Series

Food Grade Plastic | Microwave Safe | Freezer Safe | Easily Stackable

Ranging between 1 OZ - 6 OZ







## Hinge Series

Food Grade Plastic | Microwave Safe | Freezer Safe | Easily Stackable

**1 OZ**

Code: **DPH1OZ**

Colors Available:  
Transparent

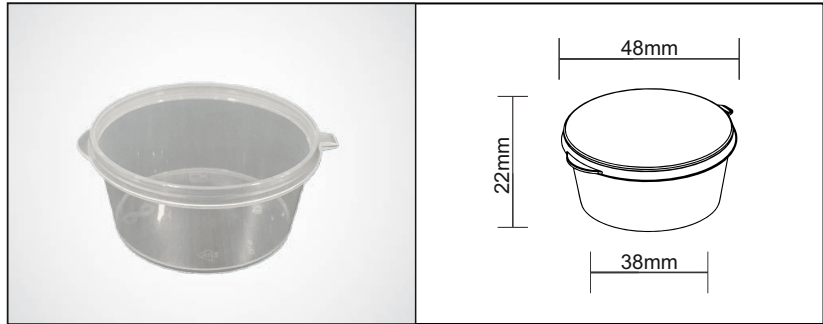

**2 OZ**

Code: **DPH2OZ**

Colors Available:  
Transparent

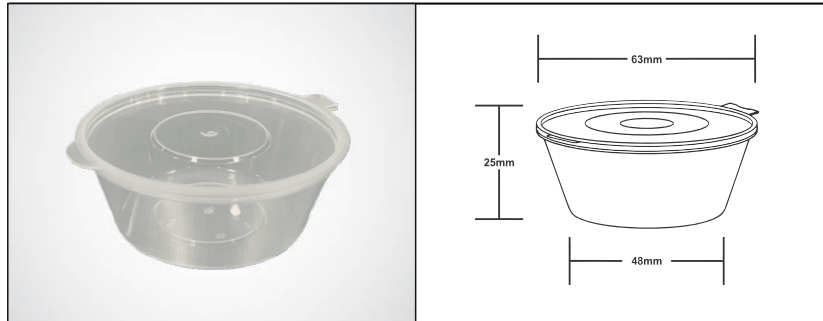

**4 OZ**

Code: **DPH4OZ**

Colors Available:  
Transparent

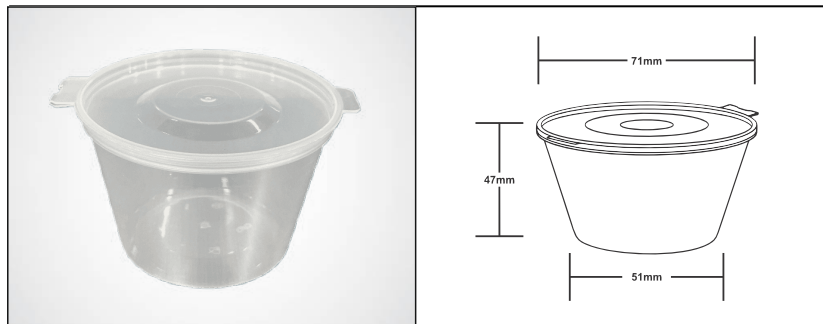

**6 OZ**

Code: **DPH6OZ**

Colors Available:  
Transparent

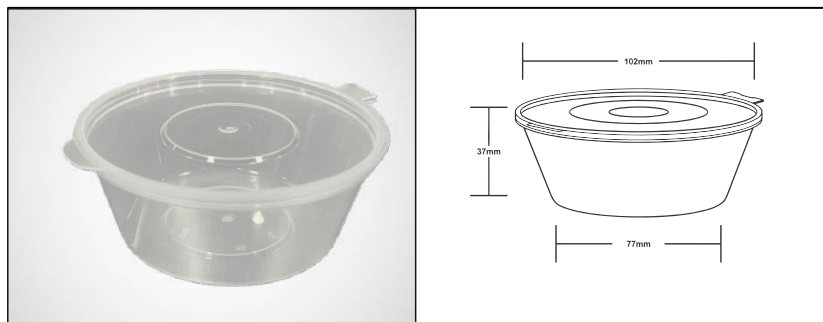



# Round Series

Food Grade Plastic | Microwave Safe | Freezer Safe | Easily Stackable

## Ranging between 2 OZ - 50 OZ







## Round Series

Food Grade Plastic | Microwave Safe | Freezer Safe | Easily Stackable

### 2 OZ

Code: **DP2OZ**

Colors Available:  
Black, White &  
Transparent

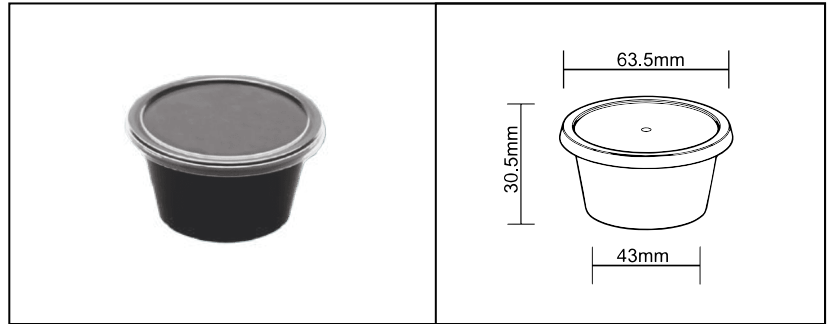

### 4 OZ

Code: **DP4OZ**

Colors Available:  
Black, White &  
Transparent

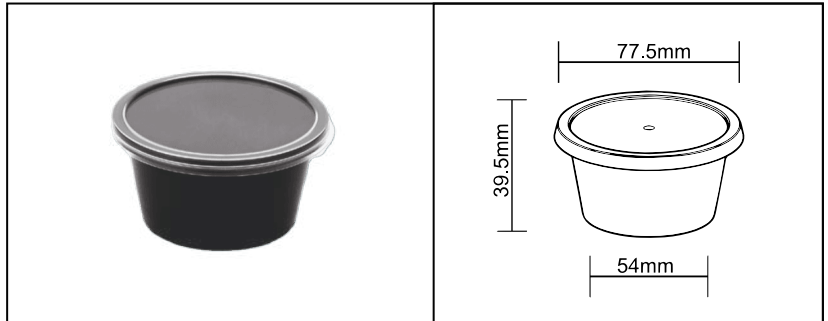

### 8 OZ TALL

Code: **DPT8OZ**

Colors Available:  
Black, White &  
Transparent



### 8 OZ

Code: **DP8OZ**

Colors Available:  
Black, White &  
Transparent

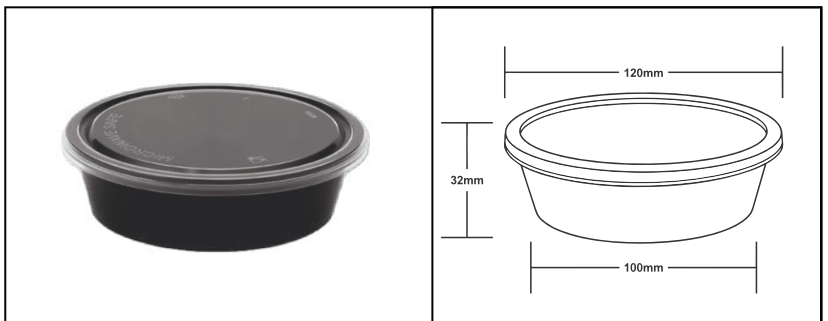



## Round Series

Food Grade Plastic | Microwave Safe | Freezer Safe | Easily Stackable

### 10 OZ

Code: **DP10OZ**

Colors Available:  
Black, White &  
Transparent



### 16 OZ

Code: **DP16OZ**

Colors Available:  
Black, White &  
Transparent

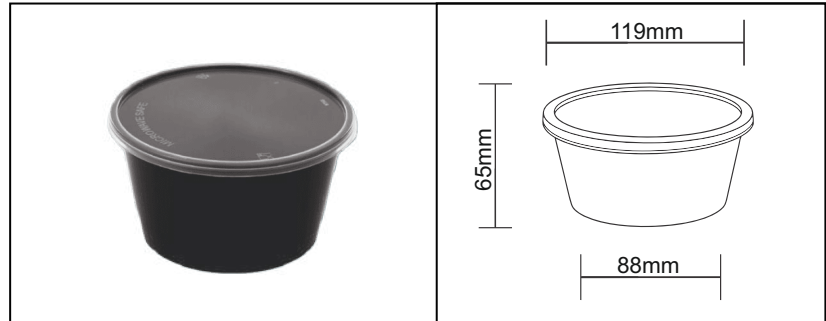

### 20 OZ

Code: **DP20OZ**

Colors Available:  
Black, White &  
Transparent

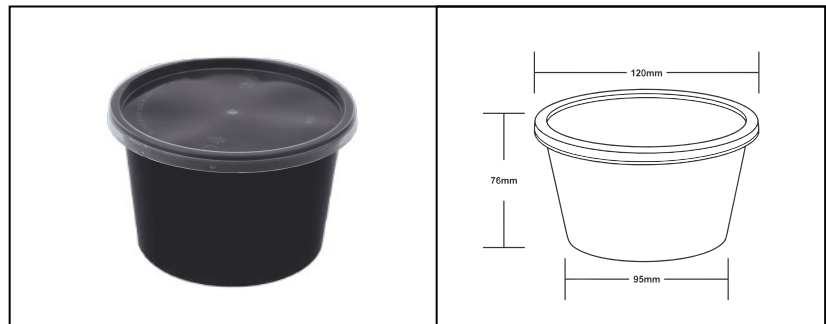

### 25 OZ

Code: **DP25OZ**

Colors Available:  
Black, White &  
Transparent





## Round Series

Food Grade Plastic | Microwave Safe | Freezer Safe | Easily Stackable

### 34 OZ N

Code: **DP34OZN**

Colors Available:  
Black, White &  
Transparent

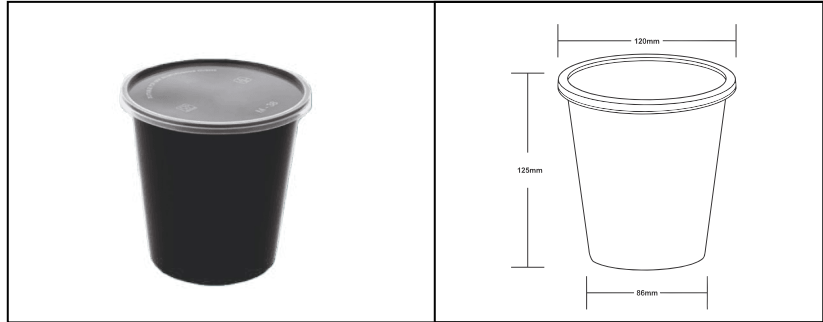

### 34 OZ L

Code: **DP34OZL**

Colors Available:  
Black, White &  
Transparent

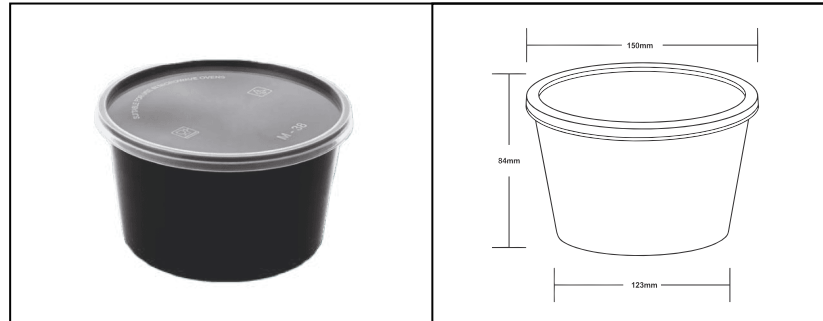

### 50 OZ L

Code: **DP50OZL**

Colors Available:  
Black, White &  
Transparent

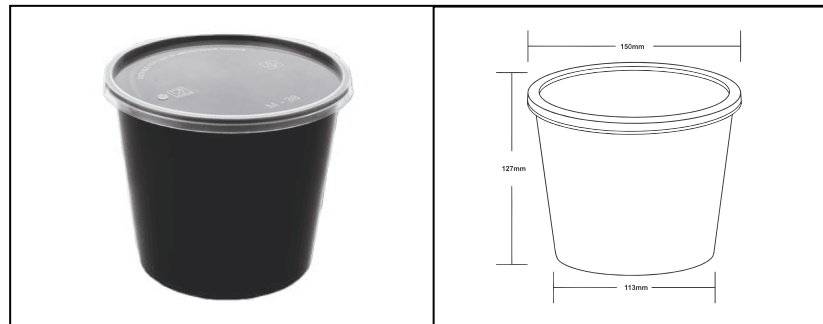

### FLAT 600 ML

Code: **DPF600**

Colors Available:  
Black, White &  
Transparent

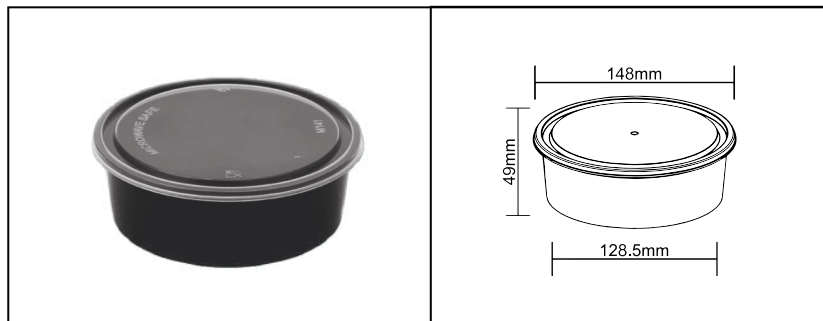



## Round Series

Food Grade Plastic | Microwave Safe | Freezer Safe | Easily Stackable

### Bowl 650 ml

Code: **DPBOWL650**

Colors Available:  
Black, White &  
Transparent

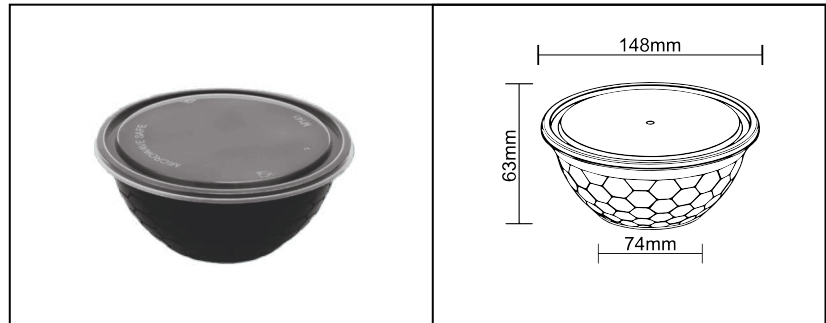

### FLAT 750 ml

Code: **DPF750**

Colors Available:  
Black, White &  
Transparent

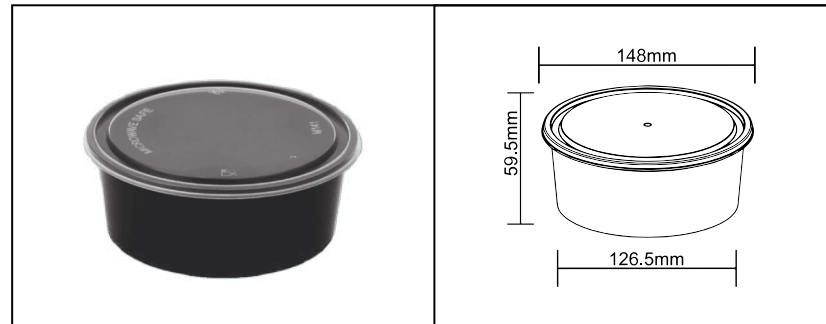

### Bowl 1050 ml

Code: **DPBOWL1050**

Colors Available:  
Black, White &  
Transparent

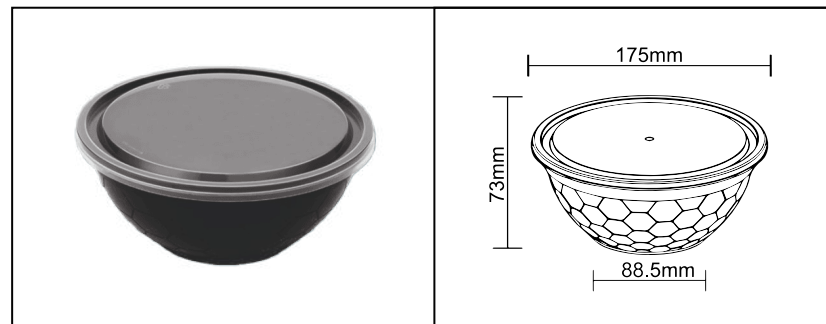





# Rectangular Series

Food Grade Plastic | Microwave Safe | Freezer Safe | Easily Stackable

Ranging between 500ml - 1500ml



# Rectangular Series

Food Grade Plastic | Microwave Safe | Freezer Safe | Easily Stackable

## 500ml N1

Code: **DP500**

Colors Available:  
Black, White &  
Transparent

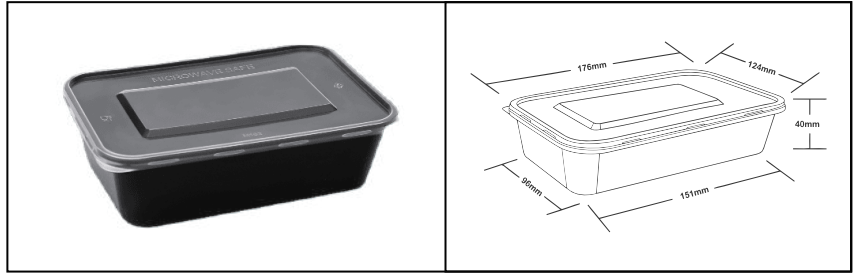

## 650ml N1

Code: **DP650**

Colors Available:  
Black, White &  
Transparent

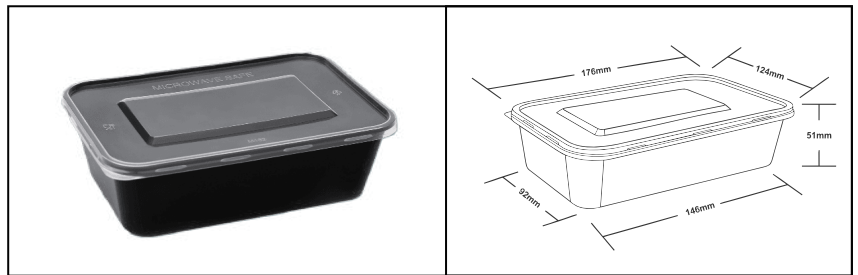

## 750ml N1

Code: **DP750**

Colors Available:  
Black, White &  
Transparent

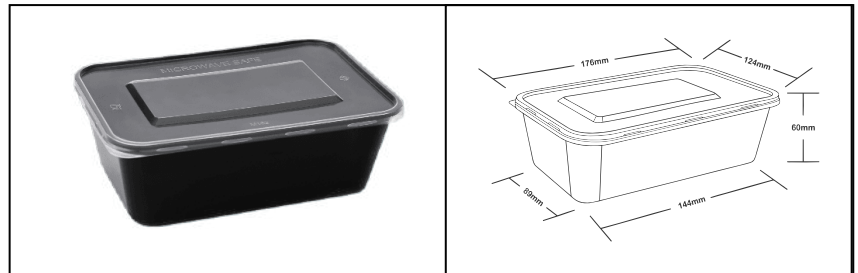

## 1000ml N1

Code: **DP1000**

Colors Available:  
Black, White &  
Transparent

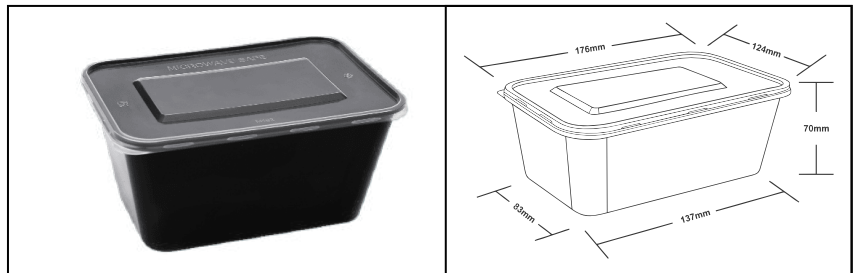

## 1500ml N1

Code: **DP1500**

Colors Available:  
Black, White &  
Transparent

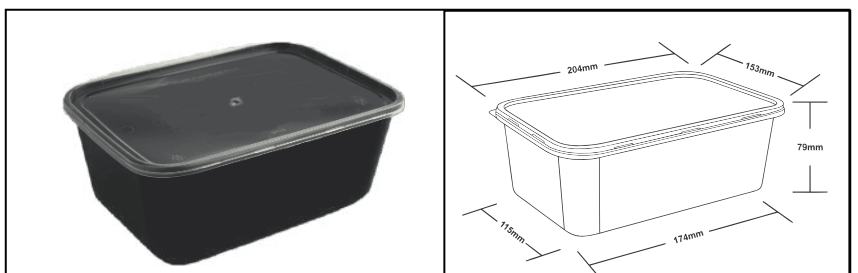





# RO Series

Food Grade Plastic | Microwave Safe | Freezer Safe | Easily Stackable

## Ranging between 16OZ - 348 OZ



# RO Series

Food Grade Plastic | Microwave Safe | Freezer Safe | Easily Stackable

## 16 RO

Code: **DPRO16**

Colors Available:  
Black & White

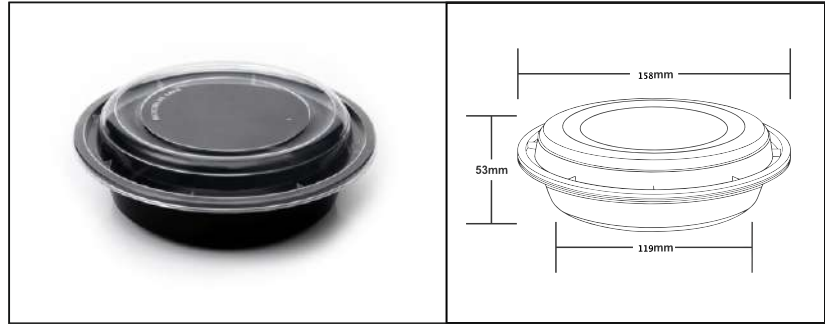

## 24 RO

Code: **DPRO24**

Colors Available:  
Black & White

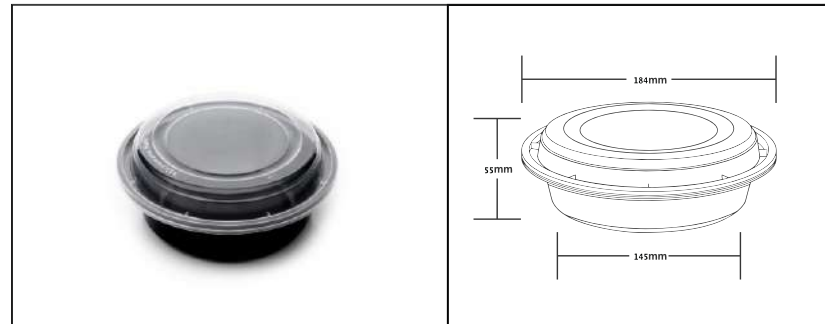

## 32 RO

Code: **DPRO32**

Colors Available:  
Black & White



## 37 RO

Code: **DPRO37**

Colors Available:  
Black & White





# RO Series

Food Grade Plastic | Microwave Safe | Freezer Safe | Easily Stackable

## 40 RO

Code: **DPRO40**

Colors Available:  
Black & White



## 48 RO

Code: **DPRO48**

Colors Available:  
Black & White

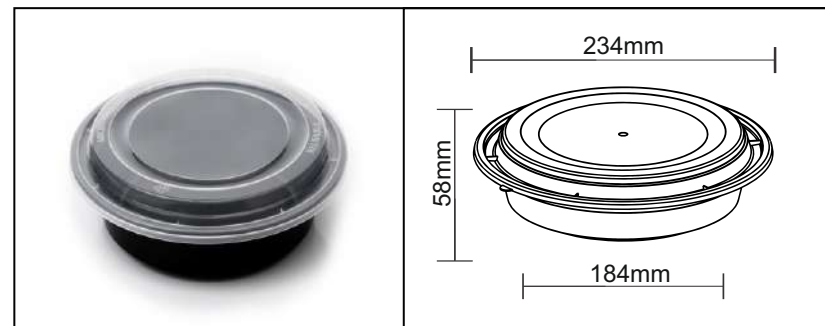

## 348 RO

Code: **DPRO348**

Colors Available:  
Black & White

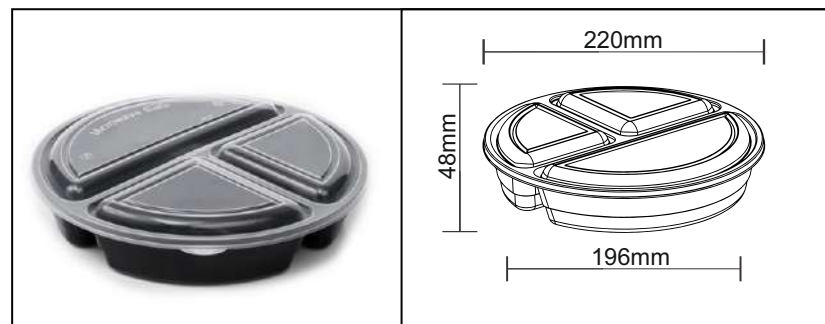





## RE SERIES

Food Grade Plastic | Microwave Safe | Freezer Safe | Easily Stackable

### Ranging between 12OZ - 342 OZ



# RE Series

Food Grade Plastic | Microwave Safe | Freezer Safe | Easily Stackable

## 12 RE

Code: **DPRE12**

Colors Available:  
Black & White

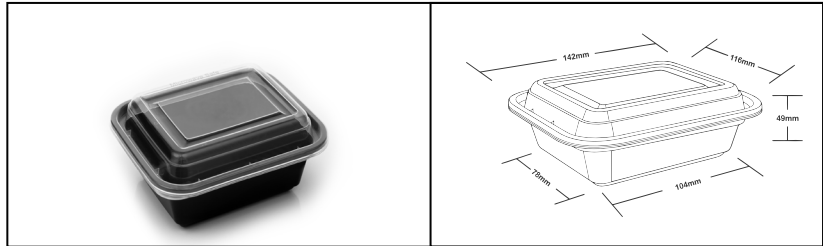

## 16 RE

Code: **DPRE16**

Colors Available:  
Black & White

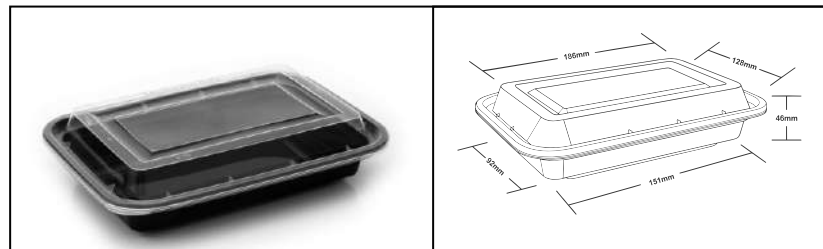

## 24 RE

Code: **DPRE24**

Colors Available:  
Black & White

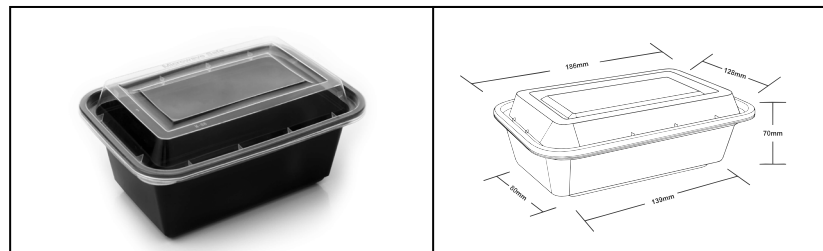

## 28 RE

Code: **DPRE28**

Colors Available:  
Black & White

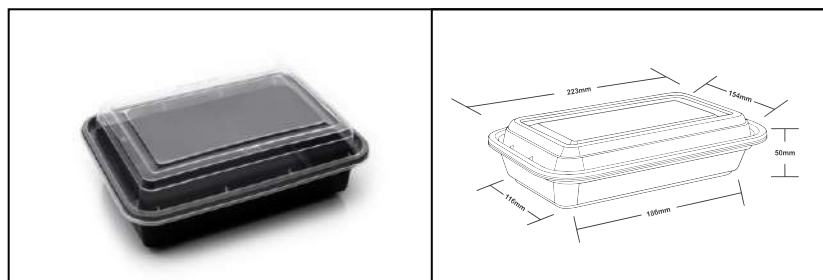

## 32 RE

Code: **DPRE32**

Colors Available:  
Black & White

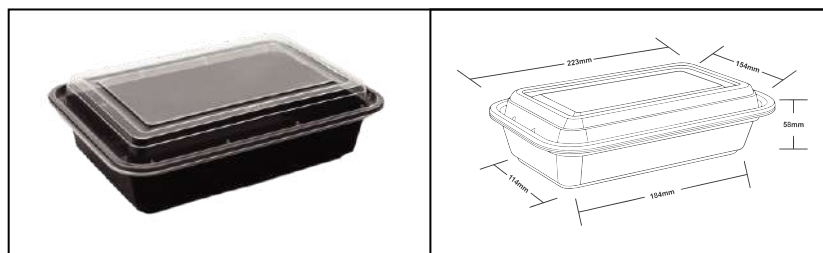

# RE Series

Food Grade Plastic | Microwave Safe | Freezer Safe | Easily Stackable

## 38 RE

Code: **DPRE38**

Colors Available:  
Black & White

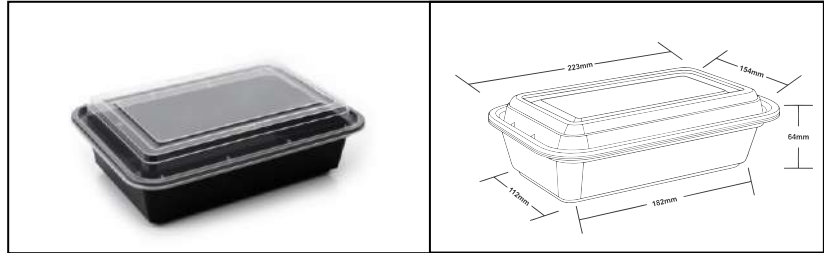

## 48 RE

Code: **DPRE48**

Colors Available:  
Black & White

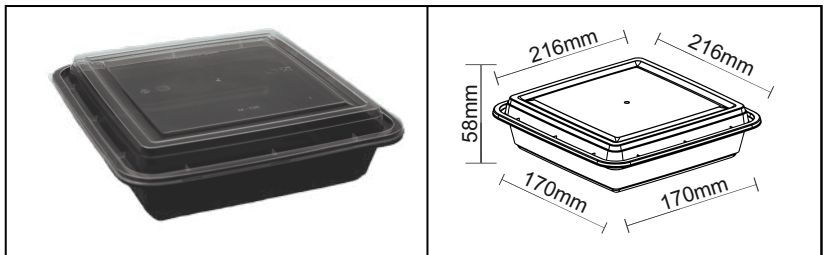

## 58 RE

Code: **DPRE58**

Colors Available:  
Black & White

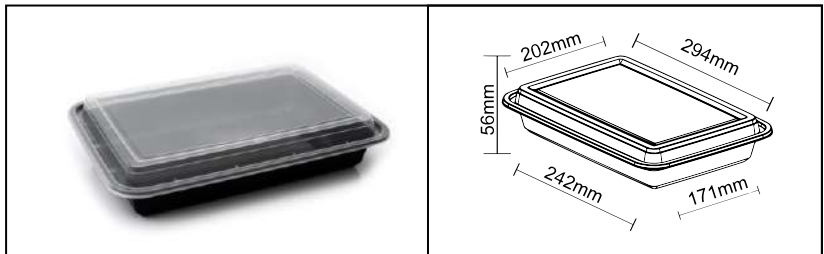

## 232 RE

Code: **DPRE232**

Colors Available:  
Black & White

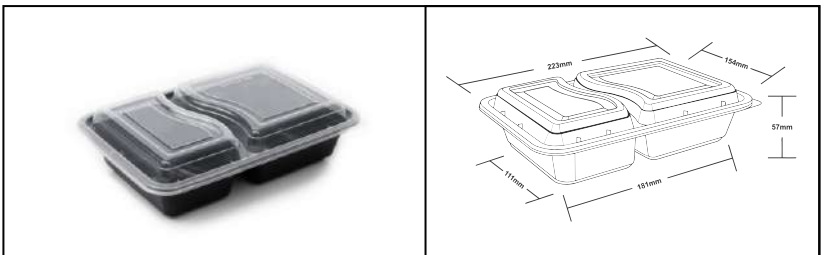

## 342 RE

Code: **DPRE342**

Colors Available:  
Black & White

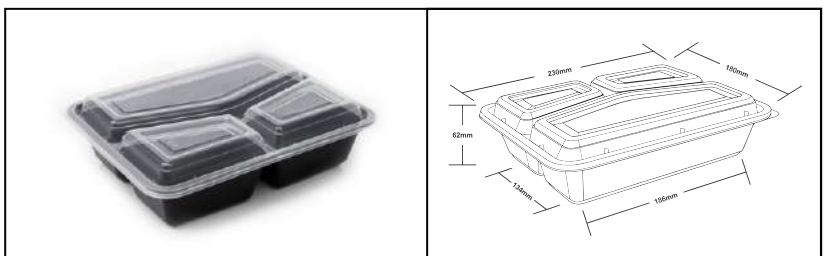





## MANGO SERIES

Food Grade Plastic | Microwave Safe | Freezer Safe | Easily Stackable

**Ranging between 750ml - 1250ml**





# Mango Series

Food Grade Plastic | Microwave Safe | Freezer Safe | Easily Stackable

**750 ml**

Code: **DPM750**

Colors Available:  
Black, White &  
Transparent

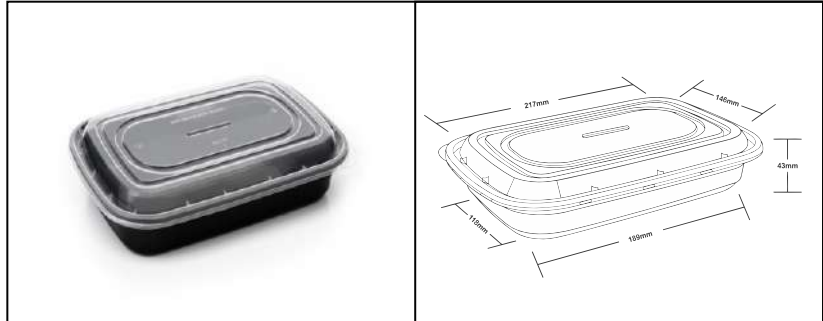

**1000 ml**

Code: **DPM1000**

Colors Available:  
Black, White &  
Transparent

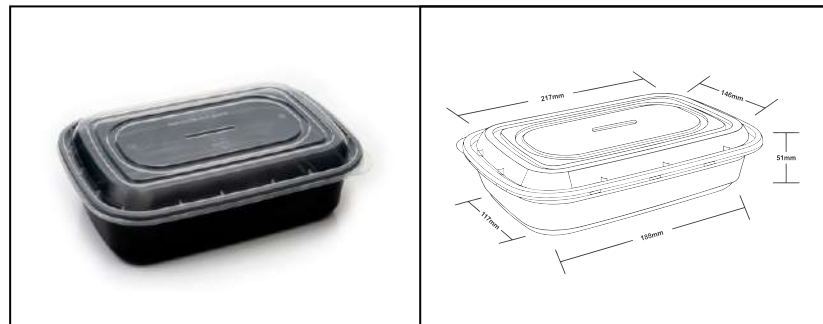

**1250 ml**

Code: **DPM1250**

Colors Available:  
Black, White &  
Transparent

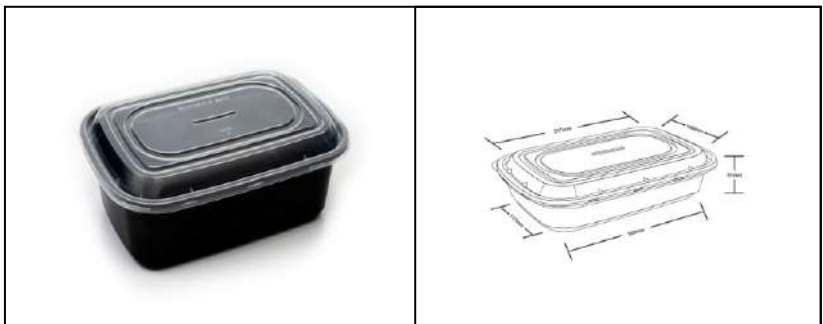



## CHERRY SERIES

Food Grade Plastic | Microwave Safe | Freezer Safe | Easily Stackable

Ranging between 600ml - 1250ml





# Cherry Series

Food Grade Plastic | Microwave Safe | Freezer Safe | Easily Stackable

**600 ml**

Code: **DPRY600**

Colors Available:  
Black, White &  
Transparent

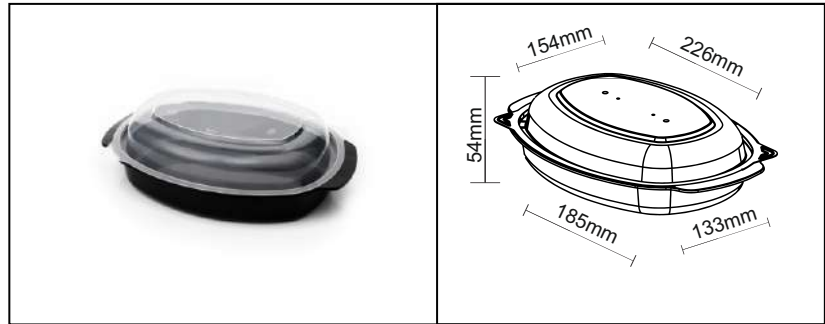

**750 ml**

Code: **DPRY750**

Colors Available:  
Black, White &  
Transparent

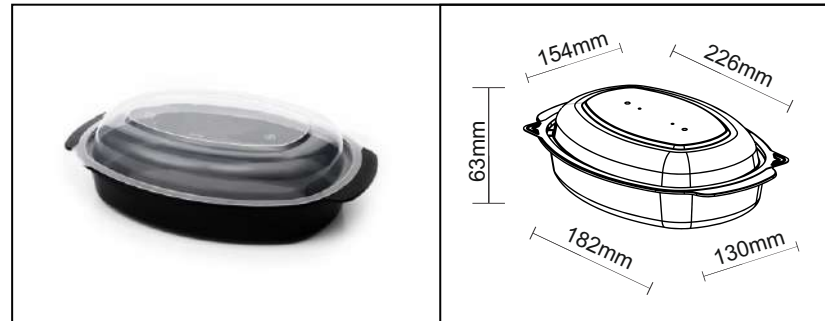

**950 ml**

Code: **DPRY950**

Colors Available:  
Black, White &  
Transparent

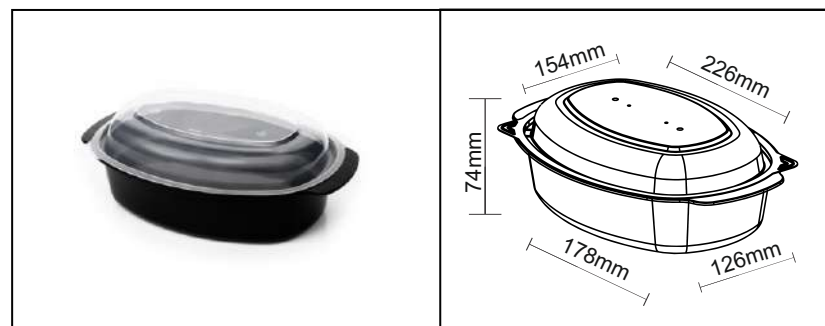

**1250 ml**

Code: **DPRY1250**

Colors Available:  
Black, White &  
Transparent





## HD SERIES

Food Grade Plastic | Microwave Safe | Freezer Safe | Easily Stackable

**Ranging between 2OZ - 4OZ  
500ml - 1000ml**



# HD SERIES

Food Grade Plastic | Microwave Safe | Freezer Safe | Easily Stackable

**20Z**

Code: **DPHD20Z**

Colors Available:  
Black &  
Transparent

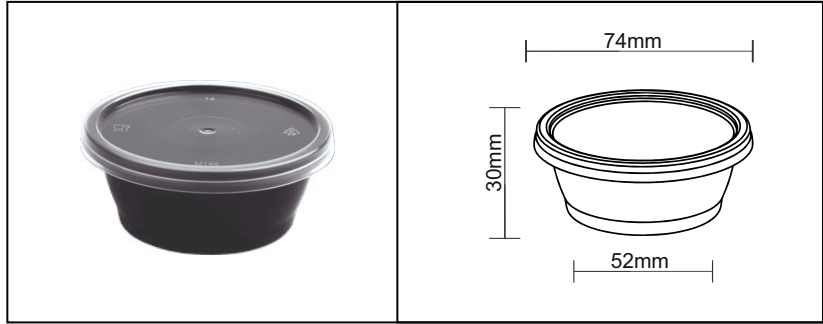

**40Z**

Code: **DPHD40Z**

Colors Available:  
Black &  
Transparent

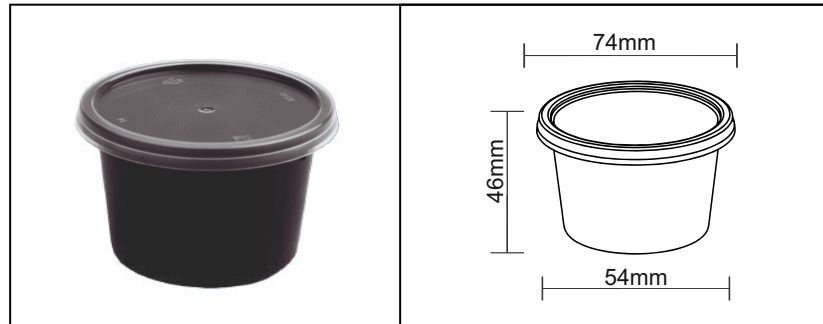

**500 ml**

Code: **DPHD500**

Colors Available:  
Black &  
Transparent

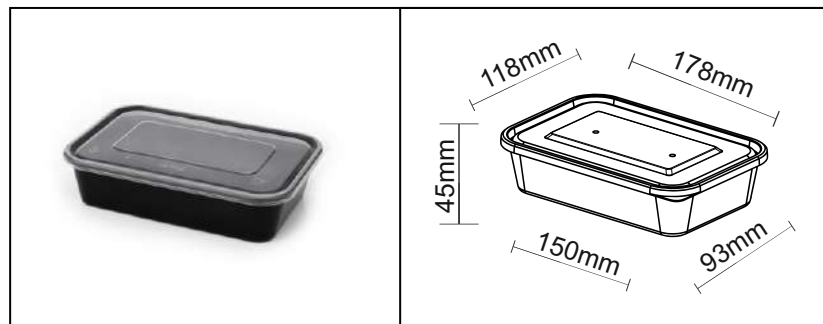

**650 ml**

Code: **DPHD650**

Colors Available:  
Black &  
Transparent

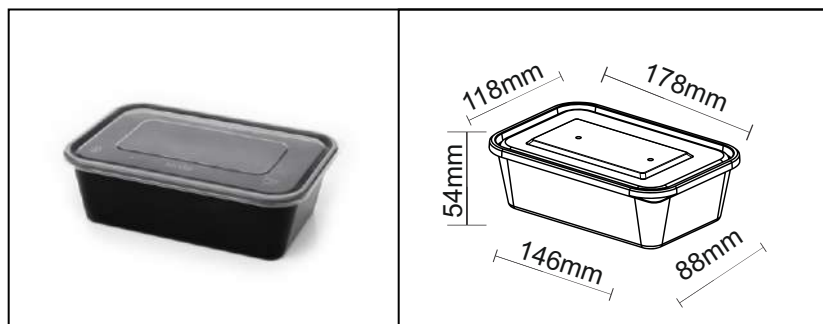



# HD SERIES

Food Grade Plastic | Microwave Safe | Freezer Safe | Easily Stackable

**750 ml**

Code: **DPHD750**

Colors Available:  
Black &  
Transparent

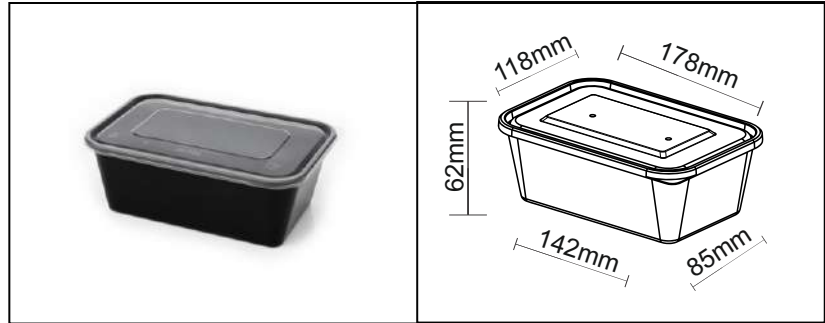

**1000 ml**

Code: **DPHD1000**

Colors Available:  
Black &  
Transparent

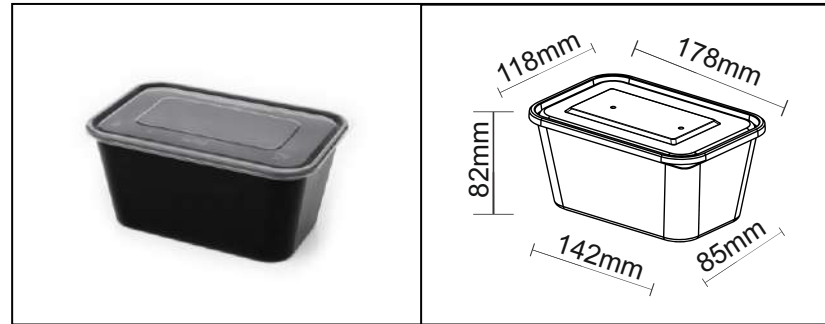



# Our Facilities:

## Factory Address :

### Unit I

Plot No 24,29,30,36 Survey No P/126, Silvassa Industrial, Co-op Soc Ltd, Amla, Silvassa, Dadra & Nagar Haveli, Dadra and Nagar Haveli and Daman and Diu, 396230 India

### Unit II:

Gala No. 004, Ground Floor, Varun Industrial Estate Survey no. 46/D1, Near Bluebell Industrial, Manus Industrial Hub Chinch Pada, Vasai East - 401208, Maharashtra

### Dubai (Warehouse) :

2505-048, Iris Bay Tower, Plot No. 236, Land DM NO: 346-745, Business Bay, Dubai, UAE

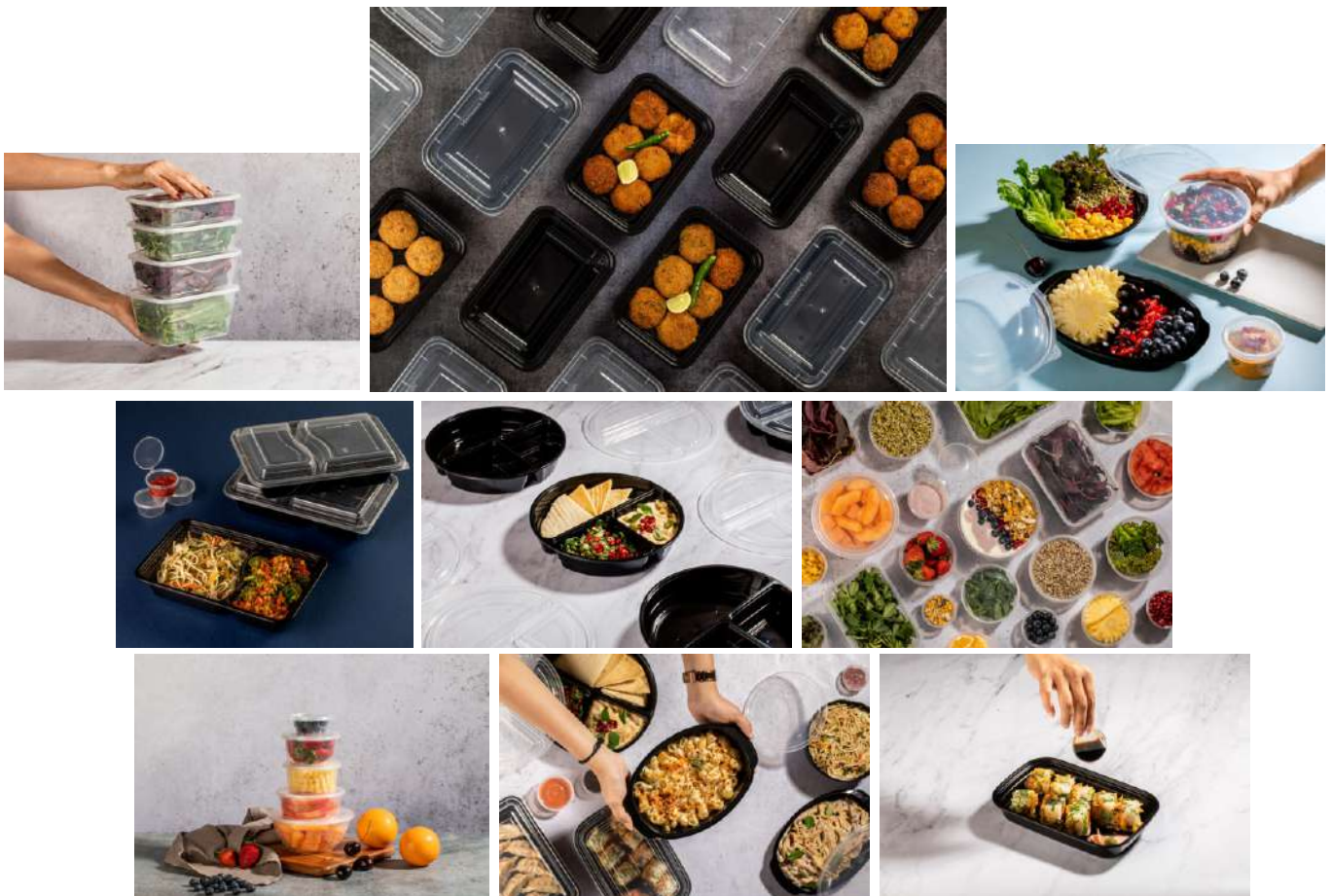



**DAMATI**

*Celebrating 20 years of Excellence*

**Mumbai Head Office**

Solitaire Corporate Park, Bldg No. 5, 1st Floor, Office No. 512,  
Guru Hargovindji Road, Chakala, Andheri East, Mumbai – 400 093. India.  
Reach us: [info@damati.com](mailto:info@damati.com), +91 (022) 62026200